

Doulton Kingfisher™ Under Sink System Instructions

Scan for
Multilingual
Instructions



Scan for
Installation
Videos



Filter Installation Instructions

FILTER ELEMENTS	FOR USE IN
Biotect® Ultra Biotect® Ultra SI	Doulton Kingfisher™ Doulton Kingfisher™ Biotect® Ultra SI



Tested & Certified by NSF International to NSF/ANSI Standard 42, 53, 401 and NSF/ANSI/CAN Standard 372 in the Doulton Kingfisher™ for the reduction claims specified on the Performance Data Sheet and at www.nsf.org

Figure 1

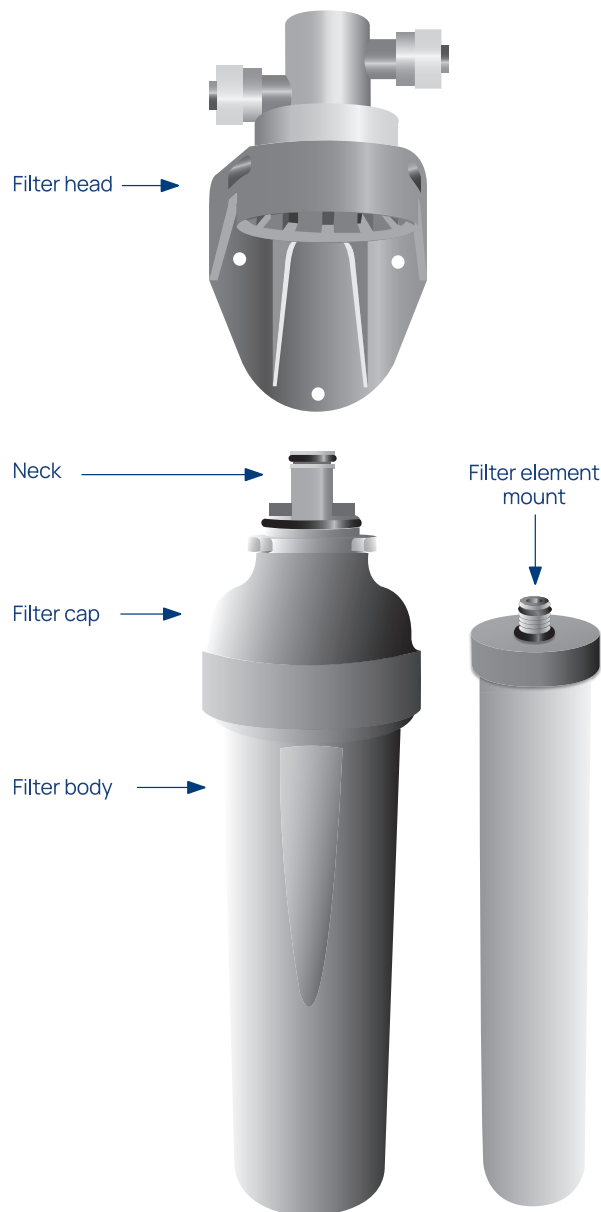

PLEASE NOTE: Licensed plumber installation might be required

- it is important that local laws and regulations are observed and that all selected fittings comply with such regulations.

Operating conditions

Replacement Filter Elements:

Biotect® Ultra

Biotect® Ultra SI

Rated Service Flow: 1.9 litres/min. (0.5 USG/min.)

Rated Capacity: 2300 litres (600 USG)

Maximum Working Pressure: 90 psig (620kPa)

Maximum Working Temperature: 30°C (86°F)

Minimum Operating Pressure: 20 psig (138kPa)

Minimum Operating Temperature: 5°C (41°F)

Do not use where water is microbiologically unsafe or of unknown quality without adequate disinfection before or after the systems.

Systems Certified for Cyst Reduction may be used on disinfected water that may contain filterable Cysts.

The substances reduced by this device are not necessarily in your water.

Important

1. This filter is intended for installation under the sink away from direct sunlight.
2. This filter is not designed for the treatment of hot water and should only be connected to the cold water supply.
3. It is important to wear rubber gloves or wash your hands thoroughly before and after servicing the filter.
4. Care must be taken at all times to prevent contamination of the neck of the filter cap and stem of the filter element mount by contact with unfiltered water or dirty hands after cleaning the filter element surface.

Connecting Pipework and Fittings for the 3/8" model:

The filter is supplied with pushfit connections. Medium density polyethylene tubing from a reputable supplier is recommended. An isolation valve and non-return valve should be fitted upstream of the filter (these are required by law in the UK).

The isolation valve may be used to regulate the maximum flow rate in accordance with the requirement of the filter element used. Having selected the appropriate fittings, a user valve/faucet should be installed in accordance with the manufacturer's instructions in a convenient position and then connected downstream of the filter.

Detailed guide to fitting the filter element - figures 2, 3, 4 & 5

1. Locate the filter in an upright position near to the incoming cold water supply and the user tap/faucet.
2. Ensure that the connecting pipework will not have any sharp bends in it and allow at least 100mm (4") of clearance below the assembled filter for removal of the cartridge to service or replace - see figure 2. Mark the required head position for fixing.
3. Grip the grey filter cap, twist to the 'unlock' position - see figure 3.
4. Pull down to disengage the filter cap from the head.
5. Fix the filter head to the unit or wall with the 3 screws provided.
6. Unscrew the filter body from the filter cap.
7. Open the filter and discard the protective bubble bag from the filter element.
8. Screw the threaded element mount stem into the grey cap until washer resistance is felt. **Do not over-tighten** - see figure 4.
9. Screw the white filter body into the grey filter cap until a positive stop is felt - see figure 4. **NOTE:** The inside of the filter cap is greased. Before screwing together ensure no dirt or particles are stuck to either the filter cap or filter body 'O' ring.
10. Align the arrows to the unlock position and push the assembled filter firmly into the head until it clicks into position - see figure 5.
11. Twist the white filter body until the locked position on the head is reached - see figure 5.
12. Check that the arrows align to ensure that the filter is fully locked - see figure 5.

Connecting the filter

Turn off the cold water supply and connect the inlet tubing to the inlet port of the filter. Connect the outlet tubing to the other side of the filter - see figure 6. Check that the arrows on the ports of the head are pointing in the correct direction of flow and that the tubing is pushed into the fittings to a minimum of 18mm (0.75") depth.

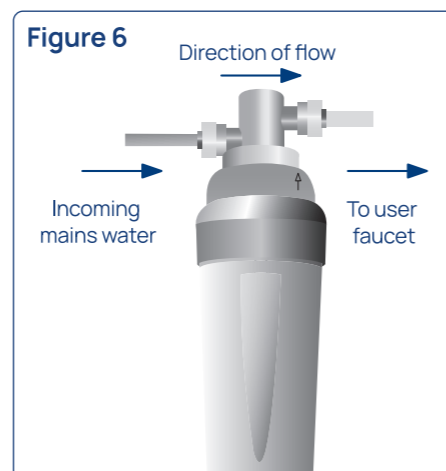
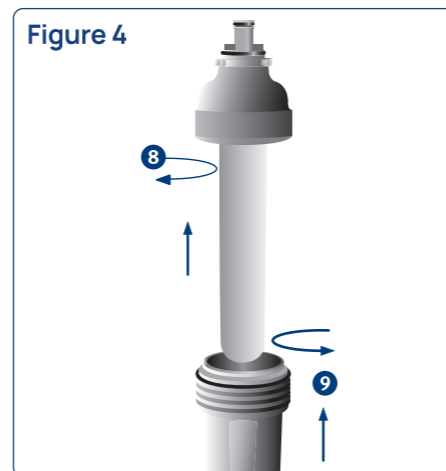
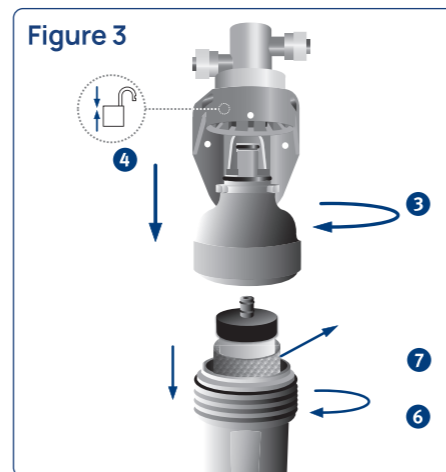
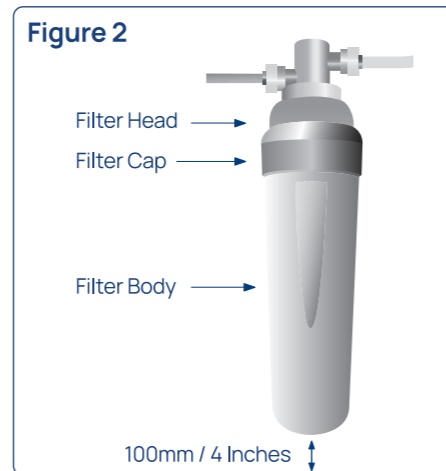
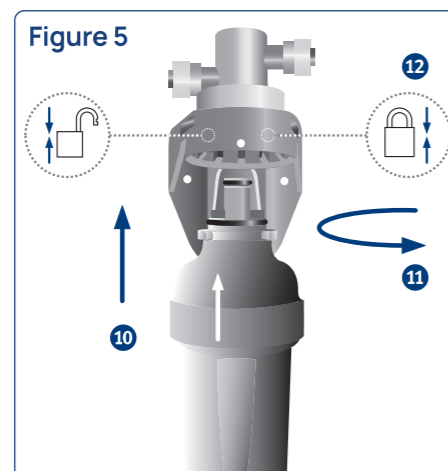

Prepare filter for use

1. With the user faucet open, slowly turn on the mains water to allow the system to fill gradually and run the filtered water to waste for 10 minutes (or 15 litres).
2. Close the faucet and check for leaks.
3. Leave to stand for 24 hours to condition the ceramic filter element, then run water to waste for a further 10 minutes. The filter is now ready for use.

Servicing the filter - removal of the filter element

1. Grip the textured rim of the grey filter cap, twist to the 'unlock' position, taking care not to trap fingers and pull down to disengage - see figure 7.

NOTE: If filter has had little use prior to servicing, twist to the 'V' vent position and open the user faucet (to relieve pressure in the filter) twist the grey cap to the 'unlock' position and pull down to disengage the filter whilst the faucet remains open.

2. The water supply is automatically turned off when the filter is dismantled. **NOTE:** If filter is to be left unattended whilst dismantled for an extended period of time (i.e. over 1 hour) then the upstream mains water supply should be isolated.

3. Take the dismantled filter body to the sink - remembering that it is still full of water.

4. Unscrew filter cap to remove the filter body and empty the water into the sink, taking care not to contaminate the open ended neck of the filter cap with unfiltered water

5. Disconnect the filter element by unscrewing and pulling down whilst holding the filter cap. Care must be taken to prevent contamination of the neck of the filter cap and filter element mount stem.

6. Replace the filter element or clean as described in the following section and then wash your hands.

NOTE: If replacing with a new filter element, prepare the filter for use as described in the 'prepare filter for use' stage above, or as per the **Operating and Exchange Instructions** supplied with the filter element.

Cleaning the filter element - figures 8 & 9

Due to filtration of particulate contaminants from the water during use, the flow of the water from the filter may reduce over a period of time. To restore the water flow to its normal level, simply clean the cartridge as follows:

Hold the filter element in a bowl of water or under running water, taking care to ensure that the open ended plastic mount is clear of the water - to avoid contamination - see figure 8.

Take a clean abrasive pad in one hand and cup it around the circumference of the filter element at the top - next to the mount. Press gently onto the candle surface with the stiff abrasive pad, whilst quickly turning the element with the other hand.

Applying a gentle even pressure with the abrasive pad slowly work down the length of the filter element once, ensuring that the cleaning is uniform over the whole candle - see figure 9.

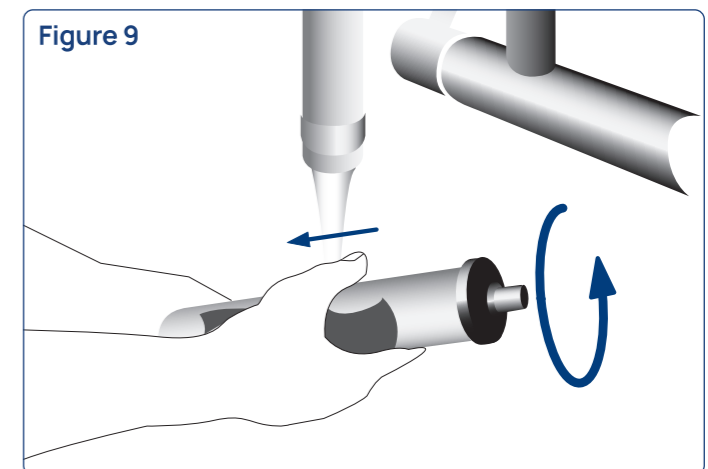
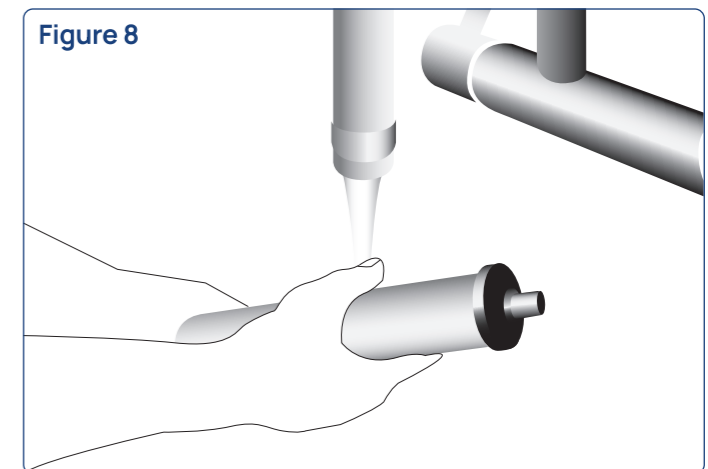
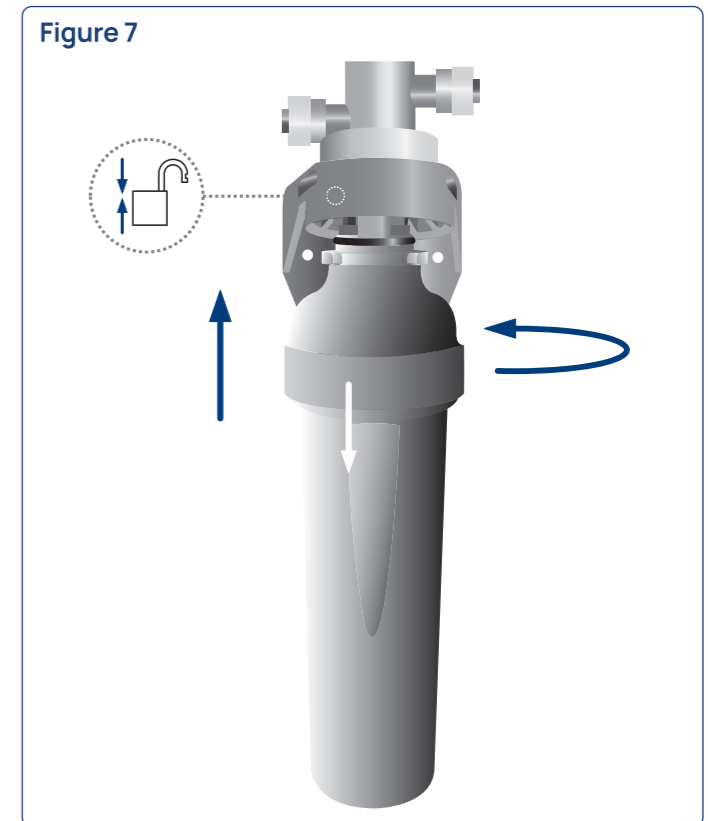

Servicing the filter - replacement of the filter element

1. Refit the filter element as follows, taking care not to contaminate the stem of the mount: Screw the threaded element mount stem into the grey filter cap until washer resistance is felt. **Do not over-tighten – see figure 10.**
2. Reassemble filter by screwing parts together until stop is reached.
3. Now wash your hands thoroughly.
4. Refit the assembled filter into the head aligning the arrows to the unlock position and push up.
5. Twist until the stop position is reached.
6. Check that the arrows are aligned at the lock symbol as illustrated in **figure 11**. At this point the water supply is automatically restored.

Cleaning the system

NOTE: The filter housing seals and seal faces are lubricated with silicone grease to ensure that they remain water tight. Care must be taken **not to remove** the silicone grease during cleaning.

To clean your housing wipe externally with a warm damp cloth.

The following substances should be avoided:

- Strong oxidising agents such as bleach or Milton solution
- All strongly acidic materials including some descalants
- Strongly alkaline materials

Disposal of used filter elements

To dispose of your ceramic filters responsibly, please follow these guidelines. For ceramic filters, first follow the cleaning instructions and then carefully break them to separate the plastic components (mount and internal adaptor). The ceramic and carbon elements can then be crushed and repurposed as drainage material for plant pots. Plastic components: mounts (PPO & PPE), may also be recyclable—please verify with your local recycling facilities. Ensure all parts are clean and free of residue before disposal to support efficient recycling.

Pressure information

Those filters have satisfied the NSF Standards 42, 53, 401 and NSF/ANSI/CAN Standard 372 structural test criteria. However, due to the potential wide variations of pressures from one installation to another, the manufacturer advises that if there is any concern that the system would see pressures above 90 psig (6 bar) then an approved pressure reducing valve set at 90 psig (6 bar) should be installed upstream of the filter to eliminate any extreme variations of pressure.

NOTE: Water fittings for use in permanently pressurised systems have a finite life. It is important that the plastic components in the system are replaced after 10 years usage.

Parts & service availability

Contact your local dealer/agent.

Product warranty

Your Doulton Kingfisher™ & Doulton Kingfisher™ Biotect® Ultra SI Systems are covered under warranty for 2 years from the purchase date of the product against any failure due to defect of materials, workmanship or design of the filter housing. Please retain your receipt as proof of purchase.

To register your product for warranty please visit: www.doulton.com/pages/warranty and complete the Product Registration Form including the serial number found on the cartridge body label and the date of installation.

Doulton® and Biotect® are trademarks registered to Fairey Industrial Ceramics Ltd.

W2393069-03 Fairey Industrial Ceramics Limited trading as Doulton Water Filters.

Figure 10

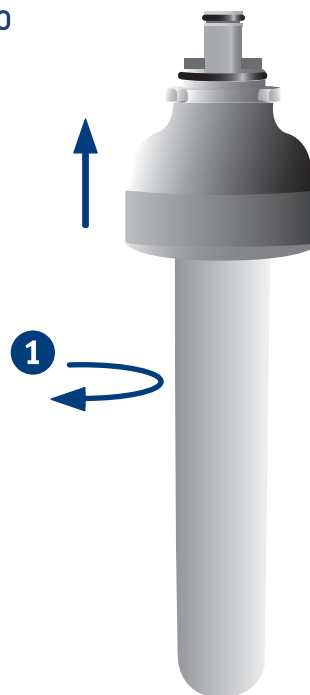
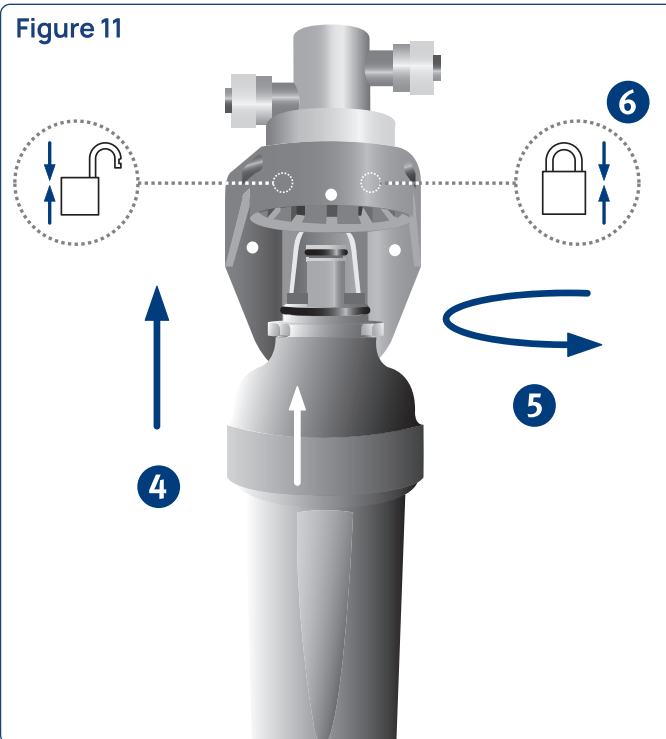

Figure 11



LEGAL DISCLAIMER

In the absence of any negligence or other breach of duty by us, the installation and use of this product is entirely at your own risk. You must at all times observe and comply with our instructions (whether set out in the appliance manual or otherwise) relating to the installation and use of this product. We will not be liable nor responsible to you for any loss or damage, legal disputes or conflicts of interests and other adverse events you suffer as a result of your failure to observe or comply with our instructions or otherwise results from your misuse or irresponsible or negligent use of the product or as a result of any events outside of our control. To the maximum extent permitted by any applicable laws, we make no warranty, representation or guarantee (whether express, implied or otherwise) regarding the fitness, merchantability, or suitability of this product for any unreasonable or unforeseeable purpose. This disclaimer does not affect your statutory consumer rights or otherwise restrict or limit any liability that we cannot lawfully exclude under any applicable laws.

Manufactured by:

Doulton Water Filters, Newcastle,
Staffordshire, ST5 9BT, United Kingdom.
Telephone: 0333 340 3600
Email: filtersales@doulton.com

Authenticate
your filter



Patent No: GB2465622

www.doulton.com



EN

Doulton Kingfisher™ Under Sink Systems

Product Data Sheet

Model: Doulton Kingfisher™ & Doulton Kingfisher Biotect® Ultra SI

Unit Description:

Doulton Kingfisher™ Under Sink System complete with Biotect® Ultra filter.

Doulton Kingfisher™ Biotect® Ultra SI Under Sink System complete with Biotect® Ultra SI filter.

General Performance:

Doulton Kingfisher™ Under Sink Systems fitted with a Biotect® Ultra filter element or Biotect® Ultra SI filter element provides the user with a point of use device capable of reducing cysts, turbidity and particles contained within a water supply.

The Biotect® Ultra and Biotect® Ultra SI elements utilise advanced carbon technology to reduce Chlorine (taste and odours) and improve taste. The incorporation of a heavy metal scavenging compound efficiently reduces lead.

During use, contaminants filtered from the water may build up on the outer surface of the ceramic elements and cause a reduction in flow through the unit. The elements will, therefore, need removing periodically for cleaning to restore the flow. Cleaning frequency will be dependent on the condition of the incoming water. An element that has reached the end of its life would be indicated by a reduction in the quality of the filtered water with respect to taste.

The elements should be replaced in accordance with the rated service capacity, which would typically give a period of six months usage.

Manufactured by:

Fairey Industrial Ceramics Limited, Newcastle, Staffs, ST5 9BT, England.

Telephone No: 0333 340 3600

Website: www.doulton.com

Parts and Service Availability:

Fairey Industrial Ceramics Limited, Newcastle, Staffs, ST5 9BT, England.

Telephone No: 0333 340 3600

For sales, service and replacement parts please contact your local Doulton® distributor.

General Product Data:

Rated service flow	1.9litres/min (0.5 USG/min.)
Rated capacity	2300 litres (600 USG)
Maximum operating pressure	*620kPa (90 psig)
Maximum operating temperature	30°C (86°F)
Minimum operating pressure	138kPa (20 psig)
Minimum operating temperature	5°C (41°F)

*See specific pressure information overleaf



System Tested & Certified by NSF International against NSF/ANSI Standard 42, 53, 401 and NSF/ANSI/CAN Standard 372 for the reduction claims specified in the performance table below.

Doulton Kingfisher™ & Doulton Kingfisher™ Biotect® Ultra SI Performance/Test Data

TEST PARAMETER	EPA MCL	INFLUENT CHALLENGE	AV. EFFLUENT	MAX. EFFLUENT	% REDUCTION (AV.)	REDUCTION REQUIREMENT	MAX PERMISSIBLE EFFLUENT
CHLORINE (TASTE & ODOUR ONLY)	N/A	2.0 MG/L +/- 10%	0.09 PPM	0.21 PPM	95.5%	>50%	/
CYST (LIVE CRYPTOSPORIDIUM PARVUM)	99.95%	≥50,000/L	6/L	14/L	>99.99%	≥99.95% PASS	/
PARTICULATE & MICROPLASTICS (PARTICLES 0.5 - 1MM)	N/A	±10,000/ML	1,583/ML	9,000/ML	>99.9%	≥ 85% CLASS 1	/
TURBIDITY (NTU)	1 NTU	11 +/- 1 NTU	< 0.1 NTU	0.1 NTU	99.1%	N/A	≤ 0.5 NTU
LEAD (6.5PH)	0.015 PPM	0.15 MG/L +/- 10%	0.0007 PPM	0.0013 PPM	99.5%	N/A	≤ 0.01 PPM
LEAD (8.5PH)	0.015 PPM	0.15 MG/L +/- 10%	< 0.0005 PPM	< 0.0005 PPM	> 99.7%	N/A	≤ 0.01 PPM

The concentration of the indicated substances in water entering the system was reduced to a concentration less than or equal to the permissible limit for water leaving the system as specified in NSF/ANSI Standards 42, 53, 372 & 401. Tested at Rated Flow, Pressure = 60 psig; pH = 7.5±1; Temp. 10-25°C

This system has been tested according to NSF/ANSI 42 and 53 for reduction of the substances above. In addition, NSF/ANSI Standard 401 for microplastic reduction and NSF/ANSI/CAN Standard 372.

The compounds certified under NSF/ANSI 401 have been deemed as 'incidental contaminants/emerging compounds'. Incidental compounds are those compounds that have been detected in drinking water supplies at trace levels. Whilst occurring at only trace levels, these compounds can affect the public acceptance/perception of drinking water quality.

EN

Installation, Operation and Maintenance:

Detailed installation and operating instructions are provided with each filter unit supplied.

For general guidance, however, the main points are summarised below:

- 1 It is important that local laws and regulations are observed and that fittings comply with such regulations. The filter is to be installed on a cold water line only.
- 2 For easy servicing of the filter, there should be at least four inches of space below the filter body to allow for removal of the elements.
- 3 When the filter is installed, to ensure that the filter is conditioned to the local water supply, the filter should be flushed for a minimum of 10 minutes, and allowed to stand for 24 hours with a further short flush (10 minutes) of water to waste, after which the filter will be ready to perform at its very best.
- 4 The filter is designed so that the elements can be removed for cleaning or replacement by disengaging the filter body from the filter cap and unscrewing the elements. See installation instructions for full details. Cleaning is a simple operation. The surface of the elements can be scrubbed with a stiff abrasive pad to restore the flow. Re-installation can be carried out by screwing the elements into the cap and following steps 9-12 of the installation instructions.

Pressure information:

The units have satisfied the NSF Standards 42, 53, 401 and NSF/ANSI/CAN Standard 372 structural test criteria. However, due to the potential wide variations of pressures from one installation to another the manufacturer advises that if there is any doubt that the system would see pressures above 90 psig (6 bar) then an approved pressure reducing valve set at 90 psig (6 bar) should be installed upstream of the filter to eliminate any extreme variations in pressure.

NOTE: Water fittings for use in permanently pressurised systems may have a finite life. It is important that the plastic components in the system are replaced after 10 years usage.

Warranty:

Your Doulton Kingfisher™ & Doulton Kingfisher™ Biotect® Ultra SI Systems are covered under warranty for 2 years from the purchase date of the product against any failure due to defect of materials, workmanship or design of the filter housing. Please retain your receipt as proof of purchase.

To register your product for warranty please visit: www.doulton.com/pages/warranty and complete the Product Registration Form including the serial number found on the cartridge body label and the date of installation. Expected usable lifespan of the housing is 10 years.

Manufactured by:

Fairey Industrial Ceramics Limited, Newcastle, Staffs, ST5 9BT, England.

Telephone No: 0333 340 3600

Website: www.doulton.com

Doulton® and Biotect® are trademarks registered to Fairey Industrial Ceramics Ltd.

Certification:

Tested & Certified by NSF International to NSF/ANSI Standard 42, 53, 401 and NSF/ANSI/CAN Standard 372 for the following:

- Chlorine reduction; Taste and Odour;
- Nominal Particulate reduction, Class 1;
- Turbidity reduction;
- Cyst reduction (including Giardia and live Cryptosporidium);
- Lead reduction

Do not use where water is microbiologically unsafe or of unknown quality without adequate disinfection before or after the systems.

Systems Certified for Cyst Reduction may be used on disinfected water that may contain filterable Cysts.

The substances reduced by this device are not necessarily in your water and while testing was performed under standard laboratory conditions, actual performance may vary.

Replacement Parts:

The replacement parts for this unit are Biotect® Ultra elements or Biotect® Ultra SI. Only use genuine Doulton® replacement elements to ensure optimum filter performance.

When leaving on vacation and to winterise the unit:

If you plan to be away from home for extended periods, or the filter housing may be subject to the risk of freezing, shut off the main water supply then disassemble the housing. When the risk of freezing subsides and you wish to use the system again turn on the main water supply and follow filter installation instructions.

PLEASE NOTE: Allowing the unit to freeze will invalidate the product warranty.